

SIDE ELEVATION OF PARALLEL DRAINAGE STRUCTURE

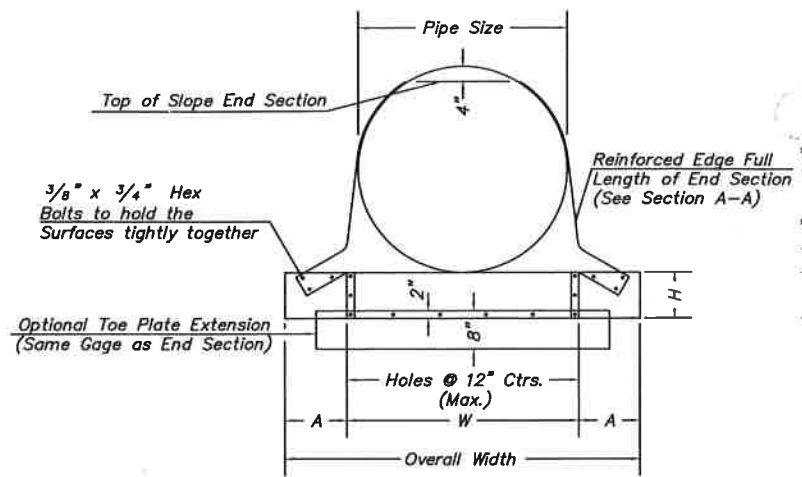

FRONT VIEW

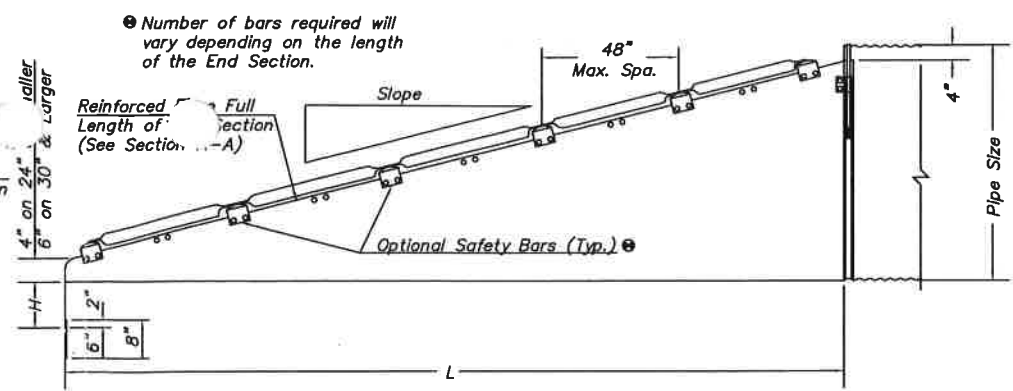

SIDE ELEVATION FOR CROSS DRAINAGE STRUCTURE

GENERAL NOTES

STEEL
Steel shall meet A.A.S.H.T.O. Specifications.

CONNECTORS
Sizes thru 24" attach to pipe with Type #1 straps. All other sizes attach with Type #2 Rods and Lugs.

TOE PLATE EXTENSIONS
When required, toe plate extensions are to be the same gage as End Section. Dimensions shall be Overall Width less 6 inches by 8 inches high.

OPTIONAL SAFETY BARS
Safety bars, when specified, shall be Schedule 40 Galvanized Steel Pipe. Pipe to be Galvanized after forming.

MISCELLANEOUS DETAILS
Details of Construction Materials and Workmanship not shown on this drawing shall conform to J & J Drainage Products Standards.

Sizes over 24" and 28" x 20" have multiple panels joined with bolts and nuts.

Slotted holes for safety bar attachment shall be provided for all End Sections.

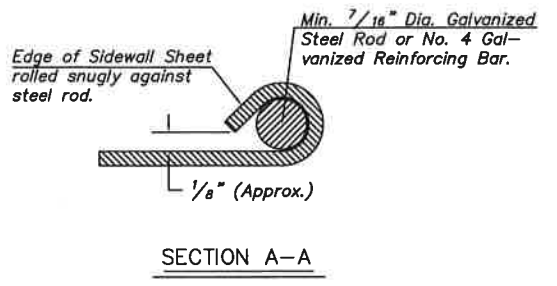

SECTION A-A

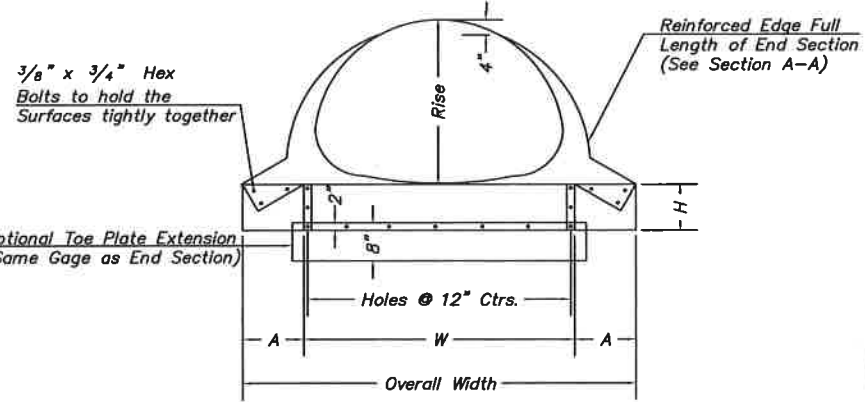

FRONT VIEW

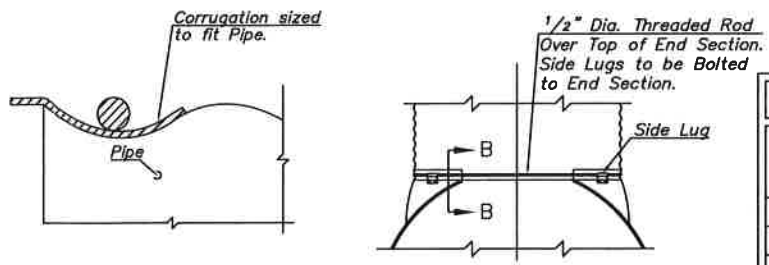

SECTION B-B

TYPE #2 CONNECTOR DETAILS

For 30" and Larger 21"x15" and Larger

Pipe Dia. (In.)	Min. Thick. In.	Gage *	Dimensions + or - 2"				L Dimensions + or - 2"					
			A	H	W	Overall Width	Slope	Length (In.)	Slope	Length (In.)	Slope	Length (In.)
15	.064	16	8	6	21	37	4:1	20	6:1	30	10:1*	70
18	.064	16	8	6	24	40	4:1	32	6:1	48	10:1*	100
21	.064	16	8	6	27	43	4:1	44	6:1	66	10:1*	130
24	.064	16	8	6	30	46	4:1	56	6:1	84	10:1*	160
30	.109	12	12	9	36	60	4:1	80	6:1	120	10:1*	220
36	.109	12	12	9	42	66	4:1	104	6:1	156	10:1*	280
42	.109	12	16	12	48	80	4:1	128	6:1	192	-	-
48	.109	12	16	12	54	86	4:1	152	6:1	228	-	-
54	.109	12	16	12	60	92	4:1	176	6:1	264	-	-
60	.109	12	16	12	66	98	4:1	200	6:1	300	-	-

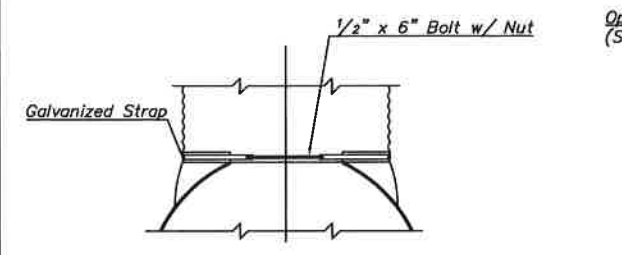

TYPE #1 CONNECTOR DETAIL

Thru 24"

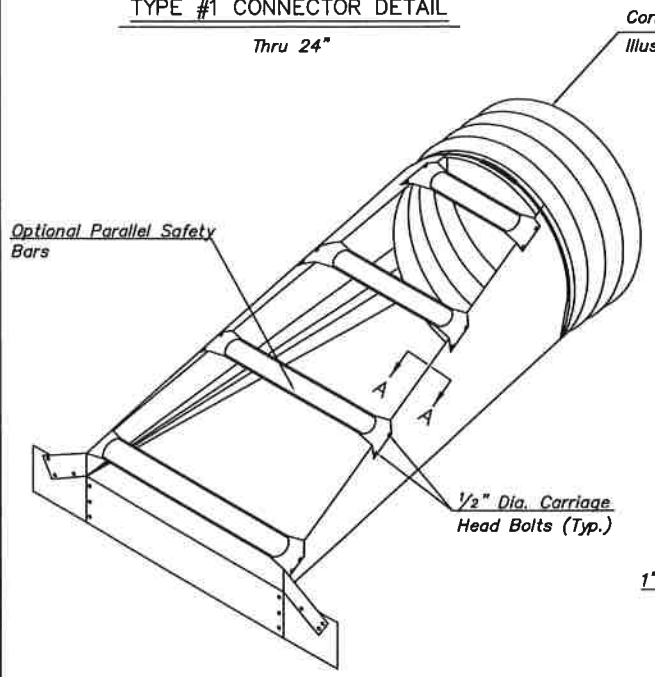

24" PARALLEL DRAINAGE STRUCTURE 6:1 SLOPE

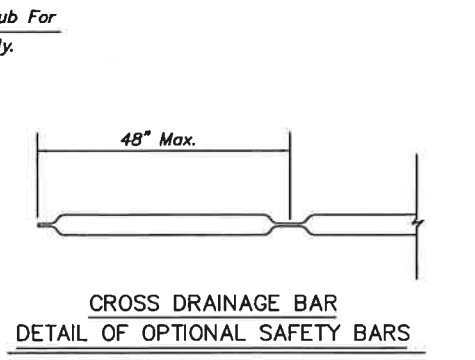

CROSS DRAINAGE BAR DETAIL OF OPTIONAL SAFETY BARS

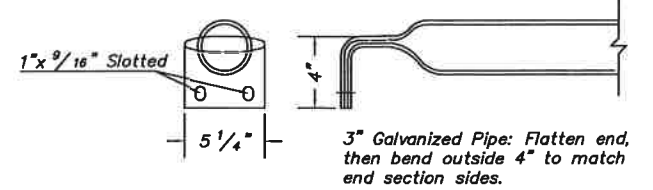

PARALLEL BARS DETAIL OF OPTIONAL SAFETY BARS

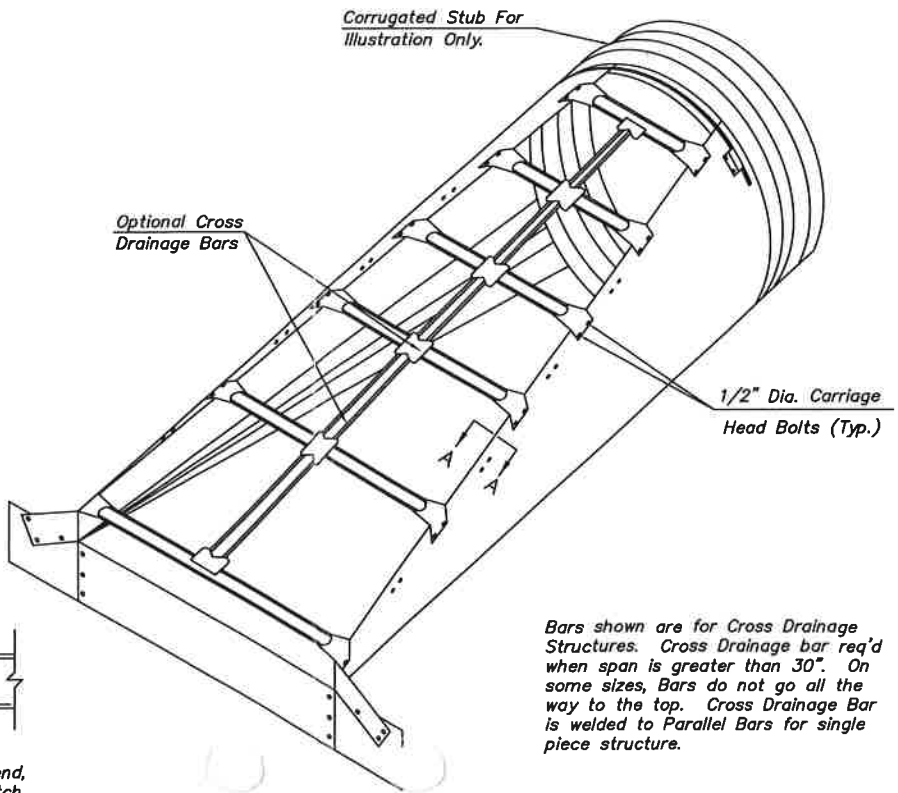

48" CROSS DRAINAGE STRUCTURE 6:1 SLOPE

Bars shown are for Cross Drainage Structures. Cross Drainage bar req'd when span is greater than 30". On some sizes, Bars do not go all the way to the top. Cross Drainage Bar is welded to Parallel Bars for single piece structure.

Eqv. Dia. (In.)	(Inches) Span	Rise	Min. Thick. In.	Gage *	Dimensions + or - 2"				L Dimensions + or - 2"					
					A	H	W	Overall Width	Slope	Length (In.)	Slope	Length (In.)	Slope	Length (In.)
18	21	15	.064	16	8	6	27	43	4:1	20	6:1	30	10:1*	70
21	24	18	.064	16	8	6	30	46	4:1	32	6:1	48	10:1*	100
24	28	20	.064	16	8	6	34	50	4:1	40	6:1	60	10:1*	120
30	35	24	.079	14	12	9	41	65	4:1	56	6:1	84	10:1*	160
36	42	29	.109	12	12	9	48	72	4:1	76	6:1	114	10:1*	210
42	49	33	.109	12	16	12	55	87	4:1	92	6:1	138	-	-
48	57	38	.109	12	16	12	63	95	4:1	112	6:1	168	-	-
54	64	43	.109	12	16	12	70	102	4:1	132	6:1	198	-	-
60	71	47	.109	12	16	12	77	109	4:1	148	6:1	222	-	-
72	83	57	.109	12	16	12	89	121	4:1	188	6:1	282	-	-

* Minimum Thickness of all 10:1 Slope End Sections is .109" - 12 Gage

4	7-00	Add 10:1 Slope & General Revisions
3	2-91	General Revisions
2	6-90	Chart Revision
1	7-89	Detail of Cross Drainage Safety Bar
No.	Date	Revisions

SAFETY SLOPE END SECTION FOR CIRCULAR & ARCHED PIPES

